



ITEM SKU#: 662187547398

Ortega Fuel Pump Canopy Light

INDUSTRIAL LIGHTING | CANOPY LIGHTS

FEATURES

- High savings in energy consumption and maintenance cost.
- Rugged body which protects the luminaire against moisture & vibration.
- Effective resistance towards common surges.
- Reliable performance even in humid environments.

APPLICATIONS

Commercial Spaces, Parking Lots, Gas Stations, Other Industrial Spaces

PRODUCT DETAILS

ELECTRICAL

Power	150 W
Voltage	100-277 V
Current	1.67 A
Power Factor	≥0.90
Total Harmonic Distortion (THD)	--

LIGHTING PERFORMANCE

Lumens	19500 lm
Efficacy	130 lm/W
Color Temperature (CCT)	5000 K
Color Rendering (CRI)	80+
R9 (Red Value)	N/A
R13 (Skin Tones)	N/A
Beam Angle	110°
Light Distribution	--
BUG Rating (Backlight, Uplight, and Glare)	--
Dimmable Lighting Control	Continuous Dimming to 10% or Below

ENVIRONMENT

Operating Temperature	-13 °F ~ +104 °F
Suitable Location	WET
Ingress Protection Rating (IP)	IP66

LIFESPAN

Average Life (Hours)	100,000
Warranty (Years)	10

COMPONENTS

LED Light Source	Lumiled 3030
Driver	Meanwell HLG

CONSTRUCTION

Housing	Aluminum and Polycarbonate
Lens	--
Base / Power Supply	Hard Wired
Finish	White
Effective Projected Area (EPA)	--
Wind Shear Rating	--

QUALIFICATIONS

Model Number	Not Qualified Yet
SKU Number	662187547398



DIMENSIONS AND WEIGHT

Length	15.11"
Height	2.75"
Width	15.11"
Net Weight (lbs)	--

PACKAGING

Box Dimensions (Inches)	16" x 16" x 5"
Box Weight (lbs)	11
Quantity Per Box	1

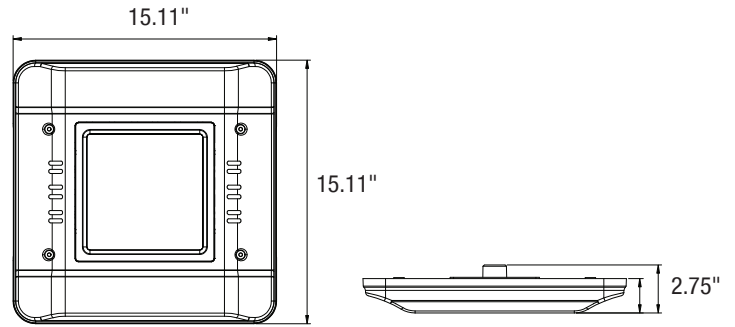

SUPPORTING DOCUMENTS

Product Sheet	View / Download
Installation Instructions	View / Download
IES Files	View / Download
LM79 Files	View / Download
LM80 Files	On Request

ORDERING INFORMATION

ITEM	DESCRIPTION	CASE
662187547398	ORTEGA FUEL PUMP: 150 W / 5000 K / 100-277 V / DIMMABLE / WHITE	1

ADDITIONAL INFORMATION:

- The mounting bracket is not included with the fixture, it is ordered as a separate item number.
- Product requires top-mounted shorting cap or optional twist-lock photocell installed to operate.