

ITEM SKU#: 662187489049

Canolux

Gas Station Canopy Light

INDUSTRIAL LIGHTING | CANOPY LIGHTS



FEATURES

- CCT and power selectable capability provides the benefit of multiple SKUs in one, reducing deadstock.
- Microwave motion sensor ensures seamless control and convenience.
- Luminous efficacy of up to 146lm/W for enhanced visibility and high energy efficiency.
- Aluminum housing with die-cast construction and a robust heat sink to ensure effective heat management and extended fixture life.
- IP65 rated to perform in wet locations and low temperatures.

APPLICATIONS

Gas Stations, Parking Lots, Garages, Walkways, Entryways, Convenience Stores, Warehouses

PRODUCT DETAILS

ELECTRICAL

Max Power	151W
Voltage	120-277V
Current	0.57A
Power Factor	0.96
Total Harmonic Distortion (THD)	5.5%
Surge Protection	L/N 6kV, L/N-P 6kV

LIGHTING PERFORMANCE

Lumens	14633lm-17559.6lm-22097lm
Efficacy	146.33lm/W
Color Temperature (Selectable)	4000K-5000K-5700K
Color Rendering (CRI)	83
R9 (Red Value)	7
R13 (Skin Tones)	83
Beam Angle	120°
Light Distribution	Type V, Very Short
BUG Rating (Backlight, Uplight, and Glare)	B3-U3-G2 (100W, 120W) B4-U3-G3 (150W)
Dimmable Lighting Control	Continuous Dimming to 10% or below

*Note: Mentioned lumen output is calculated as such: 14633lm at 100W, 17559.6lm at 120W, and 22097lm at 151W.

ENVIRONMENT

Operating Temperature	-40°F ~ +113°F
Suitable Location	WET
Ingress Protection Rating (IP)	IP65

LIFESPAN

Average Life (Hours)	50,000
Warranty (Years)	5

COMPONENTS

LED Light Source	SMD2835
Driver	Sosen

CONSTRUCTION

Housing	Die-cast Aluminum
Lens	Polycarbonate
Diffuser	Clear
Power Supply	Hard Wired
Finish	White

PART NUMBER & QUALIFICATIONS

Ordering Part Number	IK-GSCL-150W-40K/50K/57K-WH
Qualified Part Number	IK-GSCL-150W-40K/50K/57K-[WH;BR;BL;C]-[S;Blank]
SKU Number	662187489049



Not all product variations listed on this page are DLC qualified. Visit <https://www.designlights.org/qpl> to confirm qualification.

DIMENSIONS AND WEIGHT

Length (Inches)	15"
Width (Inches)	15"
Height (Inches)	3.26"
Net Weight (lbs)	9.92

PACKAGING

Box Dimensions (Inches)	17.91" x 17.91" x 5.11"
Box Weight (lbs)	12.12
Quantity Per Box	1

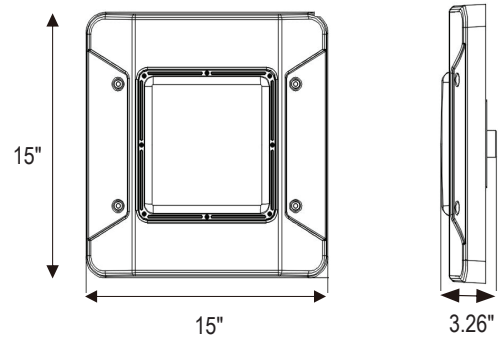

SUPPORTING DOCUMENTS

DOCUMENTS	DOCUMENT LINK
Product Sheet	View / Download
IES Files	View / Download
LM79 Report	View / Download
LM80 Report	View / Download
Installation Instructions	View / Download

ORDERING INFORMATION

SKU NUMBER	DESCRIPTION	QUANTITY/BOX
662187489049	CANOLUX GAS STATION CL: 151W / 14633-17559.6-22097LM / 40-50-57K / 120-277V / WHITE	1

ACCESSORIES

SOLD SEPARATELY

SKU NUMBER	PRODUCT CODE	DESCRIPTION	DOCUMENT LINK
662187489056	IK-HD06VCRH-7B (White)	MICROWAVE MOTION SENSOR	View / Download