

CPS Series

ITEM SKU#: 662187546988

Delphi Wall Pack (Semi Cutoff)

INDUSTRIAL LIGHTING | WALL PACKS

FEATURES

- CCT & power selectable capabilities.
- Excellent light output with even and wide distribution.
- Saves greater energy over the traditional lighting fixtures.
- Suitable for operation in low working temperature.
- Moisture & dust resistant.
- Durable die-cast aluminum housing.
- Rugged construction which makes it ideal for use in outdoor spaces.

APPLICATIONS

Building facades, commercial spaces, industrial areas, retail & hospitality buildings that demand long service life and low maintenance.

PRODUCT DETAILS

ELECTRICAL

Power (Selectable)	30 W-42 W-50 W
Voltage	120-277 V
Current	--
Power Factor	0.96
Total Harmonic Distortion (THD)	13.59%

LIGHTING PERFORMANCE

Lumens	3750 lm-5670 lm-7031 lm
Efficacy	131.17 lm/W
Color Temperature (CCT)	3000 K-4000 K-5000 K
Color Rendering (CRI)	70
R9 (Red Value)	-27
R13 (Skin Tones)	N/A
Beam Angle	360°
Light Distribution	--
BUG Rating (Backlight, Uplight, and Glare)	B1 - U3 - G2
Dimmable Lighting Control	0-10 V Dimming



ENVIRONMENT

Operating Temperature	-13 °F ~ +113 °F
Suitable Location	WET
Ingress Protection Rating (IP)	IP65

LIFESPAN

Average Life (Hours)	50,000
Warranty (Years)	5 (+5 Years Extended Warranty Option Available)

COMPONENTS

LED Light Source	--
Driver	--

CONSTRUCTION

Housing	Die Cast Aluminum
Diffuser	Glass
Base / Power Supply	Hard Wire
Finish	Bronze

PART NUMBER & QUALIFICATIONS

Ordering Part Number	IK-WPBO3M-50W-304050K-PC
Qualified Part Number	IK-WPBO3M-50W-304050K-PC
SKU Number	662187546988



DesignLights Consortium® (DLC) Premium qualified product. Not all versions of this product may be DLC qualified. Please check the DLC Qualified Products List at www.designlights.org/ QPL to confirm which versions are qualified.

DIMENSIONS AND WEIGHT

Length	14.25"
Height	7.56"
Width	9.36"
Net Weight (lbs)	--

PACKAGING

Box Dimensions (Inches)	--
Box Weight (lbs)	--
Quantity Per Box	1

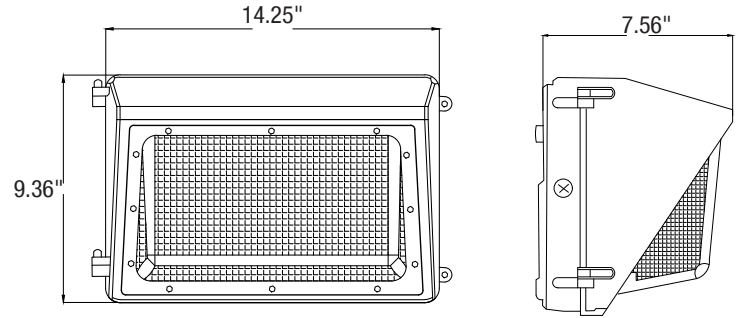

SUPPORTING DOCUMENTS

Product Sheet	View / Download
Installation Instructions	View / Download
IES Files	On Request
LM79 Files	On Request
LM80 Files	On Request

ORDERING INFORMATION (Qualified Part Number # IK-WPBO3M-50W-304050K-PC)

ITEM	DESCRIPTION	CASE
662187546988	DELPHI WALL PACK (SEMI CUTOFF): 30 W-42 W-50 W / 3000 K-4000 K-5000 K / 120-277 V / DIMMABLE / DLC	1

ACCESSORIES

662187548449	DC 12 V MICROWAVE MOTION SENSOR	1
662187548432	DC 12 V PHOTOCELL	1
662187548456	4 W EMERGENCY BATTERY BACK UP WITH CABLE	1
662187477671	SHORTING CAP	1